

KOO

KIDS

# CONTENTS

|                           |           |                     |    |
|---------------------------|-----------|---------------------|----|
| INTRODUCTION              | 1         | CURTAIN ROD STICKER | 30 |
| LOGO                      | 2         | THROW               | 31 |
| LOGO MISUSE               | 3         | RUG                 | 34 |
| COLOUR & TYPEFACE         | 4         | TOWELS              | 36 |
| ICONS & CALLOUTS          | 5         | CUSHION COVER       | 39 |
| PHOTOGRAPHY STYLING       | 6         | SWING TAG           | 41 |
| ARL INFORMATION           | 7         | STICKER             | 43 |
| SOCIAL RESPONSIBILITY     | 10        |                     |    |
| ENVIRONMENTAL CLAIMS      | 11        |                     |    |
| COLOUR CHECK              | 12        |                     |    |
| PACKAGING CHECKLIST       | 13        |                     |    |
| MANDATORY INFORMATION     | 14        |                     |    |
| <b>PACKAGING EXAMPLES</b> | <b>17</b> |                     |    |
| QUILT COVER               | 18        |                     |    |
| SHEETS                    | 22        |                     |    |
| PILLOW                    | 25        |                     |    |
| CURTAINS                  | 27        |                     |    |

# POSITIONING

KOO is the perfect choice for all. With the widest range of Home Décor bed linen, towels and home textiles, quality and style are not compromised and everything is available at a price that can enjoy.

# PURPOSE

To help people elevate their space to create a stylish, happy home they love.

KOO KIDS LOGO

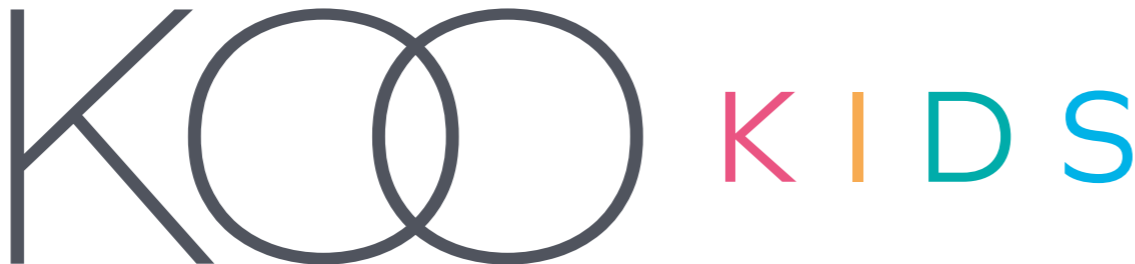

Main logo to be used on packaging. The KOO logo can be either the KOO pantone or White when placed on a coloured background as shown here.

The 'KIDS' portion of the logo is to be multi-coloured as shown. Please see colours page for CMYK breakdown of each section.

STANDARDISED SIZING ON PACKAGING



12.5mm H



15mm H

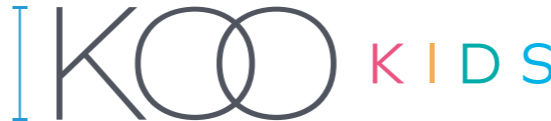

17mm H

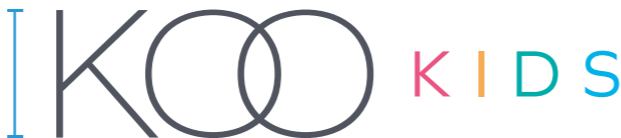

20mm H

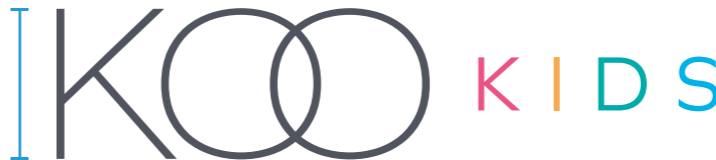

It is important that the appearance of the logo remains consistent. The logo should not be misinterpreted, modified or added to. No attempt should be made to alter the logo in any way. Its orientation, colours and composition should remain as indicated in this document - there are no exceptions.



Do not change logo colour or tone



Do not apply a gradient to the logo



Do not rotate the logo

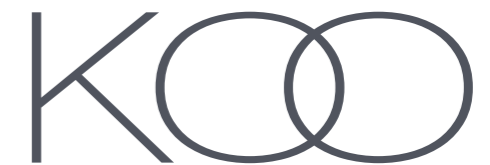

Do not distort or warp the logo in any way



Do not resolve the logo in two different colours



Do not add a stroke to the logo



Do not outline or create a keyline around the logo



Do not change the typeface or recreate the logo

# PRIMARY COLOURS & TYPEFACES



**PANTONE 7547U**

**CMYK 79 64 52 44**

**RGB 50 62 72**

\* Please note that the KOO Pantone for printed material is different to that of digital media.



WHITE

**CMYK 0 0 0 0**

**RGB 255 255 255**



**PANTONE 213U**



**PANTONE 7409U**



**PANTONE 3262U**



**PANTONE 306U**

# TYPEFACES

The primary font is Graphie, used in both bold and book fonts.

The uses of these typefaces are listed throughout the document.

Graphie Bold

**A B C D E F G H I J K L M N O P Q R S T U V W X Y Z**  
**a b c d e f g h i j k l m n o p q r s t u v w x y z**

Graphie Book

A B C D E F G H I J K L M N O P Q R S T U V W X Y Z  
a b c d e f g h i j k l m n o p q r s t u v w x y z

There are many different types of icons used throughout the KOO range.

There are size icons used for quilts, sheets and other bedding as well as other styles for couch covers and table cloths.

It is important that these are used in the correct sizing and positioning on the applicable packaging to help customers clearly see their options and help them find the correct size they need. You can find this information throughout the document under each category mentioned.

There is also a range of other icons to help customers see at a glance keys features and benefit its of many product types to be used where applicable also.

You will find examples of how these are to be used throughout the document.

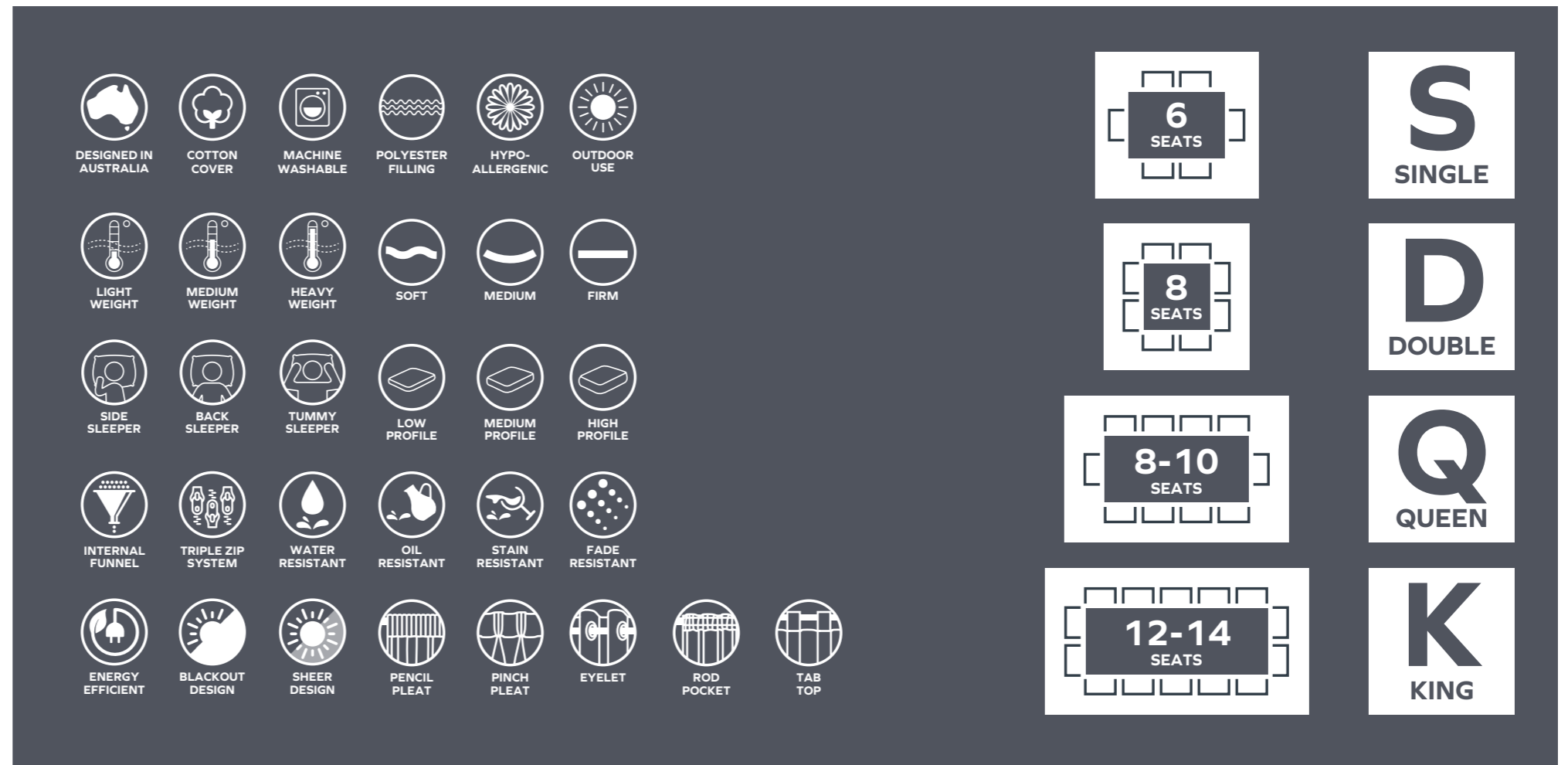

## CARD AND PAPER STOCK QUALITY/FINISH

The quality of the cardstock used within the KOO packaging range is important to maintain the high quality look of the brand.

The cardstock should have a **matte finish** and a **GSM of the stock should range between 250-400gsm** depending on the individual product. With the ideal usually being around 350gsm for most products.

There are some exceptions to this such as dinner sets and glassware set packaging which should be as thick as required to ensure the products safety as well as maintain the boxes structural integrity.

**Physical samples are to be sent for approval of quality and colour on the first run of each new set of packaging before mass production begins.**





**As part of our commitment to social responsibility, it is a MANDATORY requirement of Spotlight Group Holdings that product packaging incorporates the Australasian Recycling Logo (ARL) to help consumers recycle correctly. Use of the ARL is controlled by the Australian Packaging Covenant Organisations (APCO). This guide has been prepared to assist with adding recycling information to packaging. You must ensure that you meet all requirements as outlined on the CHECKLIST on page 4 to use the ARL on packaging and that you adhere to all APCO and ARL user guidelines.**

The ARL is a labeling program that provides the tools to designers to help consumers understand the correct disposal of packaging across both Australia and New Zealand.

**All packaging must go through PREP** (Packaging Recycling Evaluation Portal) to assess the recycling classification of each separate packaging component. Once classified, the standardised label system of ARL can be used on the packaging in conjunction with PREP. Packaging should be assessed in the state it would be after consumption. **‘Does the consumer have to remove this from the main item?’ If yes, it is a separate component.** If no, it is a secondary material.

**PREP assumes packaging is clean and empty at the time of disposal.**



**Recyclable at Kerbside**

The recyclable **‘Opaque’ mobius** communicates that consumers that item should be placed in their kerbside recycling.



**Conditionally Recyclable**

The recyclable **‘Outlined’ mobius** communicates that consumers that item is less widely accepted at kerbside and consumers should **check locally** with their council to determine suitability. This may include being accepted at an alternative location **or an ‘action’** such as ‘remove handles’ can take place by the consumer to make it acceptable at kerbside.



**Not Recyclable at Kerbside**

The bin symbol communicates to consumers to **dispose of their non-recyclable packaging thoughtfully in the general waste bin.** This symbol is also used when PREP is unable to classify recyclability due to insufficient input for evaluation. **You must complete PREP evaluations with all required information.**

**ARL Website URL**

Directs consumers to further information on recycling.

**Separate Component**

Identifies the specific packaging component the label relates to.

**Classification**

Indicates whether the packaging component is ‘Recyclable’, ‘Conditionally Recyclable’ or ‘Not Recyclable’.

**Instructions**

An approved consumer behaviour or alternative destination that improves the recyclability of the particular packaging component.

For more information on recycling visit [arl.org.au](http://arl.org.au)

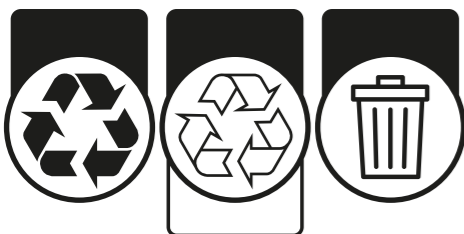

**Horizontal Arrangement**

Horizontal placement is preferred, with vertical placement a secondary option where space doesn’t allow for a consistent horizontal application.

The order of packaging components must position **‘Recyclable’ components to the left, ‘Conditionally Recyclable’ components in the middle and ‘Not Recyclable’ components to the right when horizontal.** When vertical, the ‘Recyclable’ components should be placed at the top, ‘Conditionally Recyclable’ components in the middle and ‘Not Recyclable’ Components at the bottom.

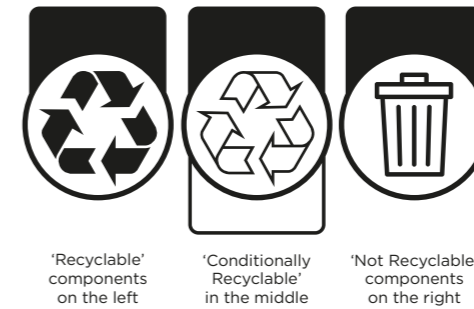

**URL Formatting**

**A URL must always be present** when using the ARL artwork to direct consumers to further information. Please refer to the below options for the use of the ARL URL ([arl.org.au](http://arl.org.au)/[arl.org.nz](http://arl.org.nz)) in correlation with the ARL artwork. If you are selling products exclusively into Australia, use the URL ‘[arl.org.au](http://arl.org.au)’. If you are selling exclusively for the New Zealand market, please use the ARL URL ‘[arl.org.nz](http://arl.org.nz)’. It is preferred that the URL is placed to the top or the right of the ARL artwork.

If products are sold to both markets, it is at the Members’ discretion to refer to the most applicable ARL URL and corresponding artwork(s). Organisations are encouraged to utilise the URL reflective of where most of the product will be sold.

There are two URL options: **‘For more information on recycling visit [arl.org.au](http://arl.org.au)/[arl.org.nz](http://arl.org.nz)’** In the case of limited on-pack labeling area, it is permitted to display only the ARL URL: **‘[arl.org.au](http://arl.org.au)/[arl.org.nz](http://arl.org.nz)’.**

**Placement**

**Placement of the ARL on-pack should reflect how the packaging will be disposed of by consumers.** Outer packaging should have the ARL on-pack relevant to all of the packaging components, whilst the inner packaging components should be labeled with their relevant ARL. For example, a box containing ice-creams will have the Box, Wrap and Stick ARL on the box, whilst the wrap is labeled with the ARL for both the Wrap and Stick (as the stick cannot be printed on individually). **This ensures relevant recycling information of packaging at the time of packaging disposal.**

## Colour

The ARL symbol may be any one solid colour provided the symbol(s) are clear, legible and compatible with the packaging background. The ARL is not permitted to be placed on a busy background. A reversed version has been created for darker backgrounds. Please note: The Recyclable ARL should always have a coloured in/opaque mobius loop, while the Conditionally Recyclable mobius loop remains transparent.

## Separable Component

This includes the main packaging and any items that will be separated by the consumer to consume the product. Each component must have an ARL symbol that is easily identifiable to the consumer.

Only one separable component is to be identified in each ARL Symbol. If the packaging is comprised of more than one separable component with the same classification you must list multiple ARL symbols.

### Best Practice

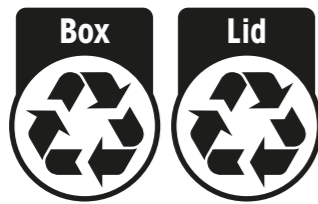

### Not Permitted



## Separable Component Exceptions

If packaging labeling real-estate is limited, only two not recyclable components can be combined within one standard ARL. Evidence of the item's limited on-pack labeling space must be kept for auditing purposes.

If you have a packaging format that is composed of multiples of the same component, these components may be labeled with one ARL provided they meet the following conditions:

- They are made of the same materials (all primary and secondary materials)
- They have the same recyclability outcome (as they are the same materials),
- The components serve the same functionality, and
- Consumers will identify them as the same component.

For example, you may have multiple 'Dividers' within a larger box - these can be represented by the one, pluralised ARL: 'Dividers'.



## Instructions

Additional information for the consumer action in order to recycle the separable component. This includes instructions for an alternative destination or to check locally for recyclability or consumer behaviour that when performed will improve the recyclability of the packaging. See approved Consumer Behaviours for acceptable actions.

## Approved Consumer Behaviours

There are several Approved Consumer Behaviours supported by APCO and PREP that will increase the recyclability of an item. The common items that require consumer behaviours to be recycled are advised with the PREP Recyclability Evaluation Report.

The instructional text, when placed on-pack, can be wrapped to fit across a maximum of three (3) lines.



### Cardboard: Flatten to Recycle

Applies to cardboard cartons that may not readily crush in a recycling truck such as those used for the storage of electronic equipment. 3D cardboard may travel to plastics stream.



### Aluminum Foil: Scrunch into Ball or Fold to Recycle

Applied to aluminum foil as 2D foil will travel to the paper stream at a Material Recovery Facility (MRF). Ball must be at least 20mm in two dimensions, when 'scrunched', to be recycled.

For items that are larger than 200mm in two directions and will be screened out at the cardboard (OCC) stage of a MRF. When folded once, it must have two dimensions <200mm and must retain these dimensions.



### Small Paper: Place in Used Envelope

Small paper items will be blown away at the recycling facility and not be recovered. Placing them in a used envelope will allow the small paper items to be recovered.



### Less Widely Accepted Packaging Items: Check Locally

For items where the council collection status falls within the Less Widely Accepted thresholds (where between 60-80% in Australia, and 50-80% for New Zealand, of the population have access to a kerbside service). Consumers will need to check with their local council to determine if these materials are accepted in their kerbside recycling bin.



### Comprised of 'Other' Materials: Remove Component

Applicable to packaging that has an attachment that does not meet the secondary material thresholds for recycling the main packaging item. For example, paper bag with material handles. The 'Component' must also be labeled separately to direct the consumer of that item's disposal method.

## DESIGN

The below design considerations must be adhered to when applying the ARL artwork to product packaging.

- Font for the separable component name, URL and any consumer instruction **text must be ITC Avant Garde Gothic, Demi Condensed**.
- The minimum text size for the **component name and URL text is 2mm in height**. For the conditional recyclability instructional text, this can be reduced to a minimum of 1.4mm in height where space is limited. This height is reflective of the tallest uppercase letter.
- There is no maximum text size requirement.

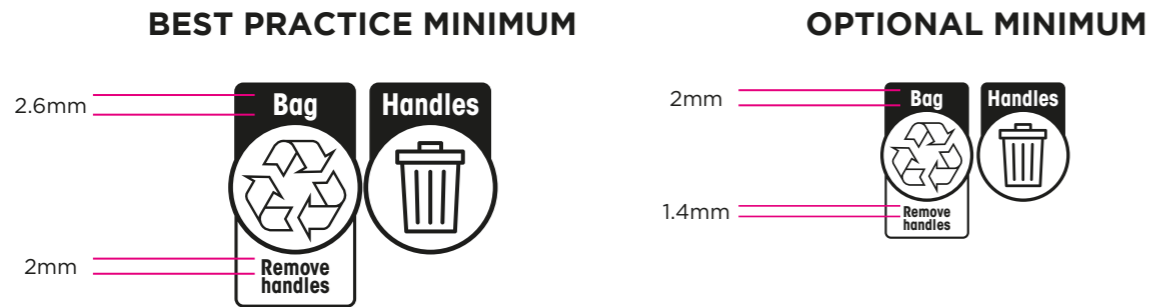

- For larger pack sizes, we recommend that the text size of the ARL be that similar to other text on pack to ensure consumer awareness and legibility.

Members must use the ARL artwork EPS files as they appear when downloaded or as sent by APCO. The ARL **designs must not be altered**, this includes maintaining the Width Depth ratio of the artwork (not including the instructional tab).

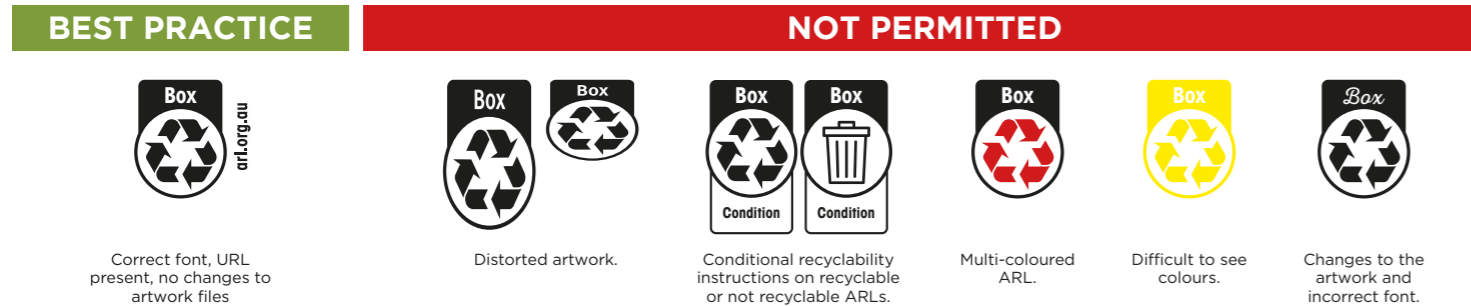

Whilst there is no set location required for the ARL on-pack, the **ARL should always be positioned in an easily accessible position, more than likely placed close to the barcode** where consumers are familiar with locating recycling information or are able to find at the time of disposal.

**The minimum size for the ARL artwork is 12mm high (not including the consumer instructions tab).**

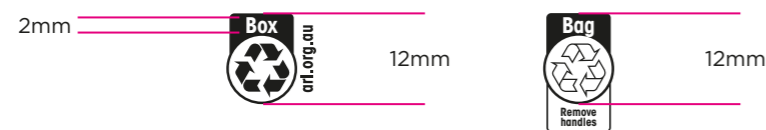

## MICRO ARL STYLE GUIDE

For small packaging projects **where on-pack labeling area is limited**, the Micro ARL may be suitable for use. All User Guide specifications are also applicable to the Micro ARL. The exemption however is that the height of the symbols can be **decreased past 12mm, to as small as 8mm, and the component name text can be reduced to 1.4mm**

Components that are conditionally recyclable are able to be labeled utilising the Micro ARL, however the consumer instructions must still meet the 1.4mm text height requirements.

There are three conditions associated with the use of the Micro ARL:

- It can only be used when the **external surface area of the packaging is less than 100cm<sup>2</sup>**
- The separable **component name can have no more than four letters**. The Member will need to select the separable component name from the approved components list and if it is longer than 4 letters, adopt the synonym in the table, where available.

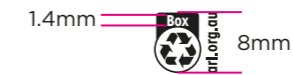

## USE WITH OTHER LOGOS

The ARL should not be used next to symbols or messaging that may confuse or unnecessarily duplicate the recycling message for consumers, such as littering symbols (e.g. tidy man logo, statements such as 'Please Recycle'), plastic identification codes, or alternative recycling symbols that have not been approved by APCO.

**Other symbols can be used on-pack but should not be used in close proximity to the ARL.**

Where possible, it is recommended that these symbols are not printed on the same face of the packaging to provide the greatest distance between labels.



## DIFFERENCES IN LABELING ACROSS COUNTRIES

In some instances, the results for packaging sold in both Australia and New Zealand may be different. **To communicate these differences and to indicate where these labels are applicable, organisations can use the ISO standard naming convention with 'AUS' and 'NZ' above the relevant ARL.** This can also be used for those packaging items that may be exported out of Australia and New Zealand where recyclability may differ.

As the ARL is verified by PREP, and PREP contains the recycling data and information for only Australia and New Zealand, the ARL cannot be used as a verified labeling system outside of these markets. Organisations should endeavour to ensure their packaging is labeled appropriately to avoid any potential misleading claims.



## NO POLYSTYRENE IN PACKAGING

We are taking the important step to phase out expanded polystyrene (EPS) in all packaging for products under 45kgs. This is part of a targeted approach to phase out problematic single-use plastics in packaging and aligns with government regulations coming into effect.

What is expanded polystyrene (EPS) packaging? Loose fill EPS is protective packaging typically used to protect products during transportation through void fill and cushioning. Loose fill includes packing peanuts and sheeting. Moulded EPS is protective packaging typically found in the packaging of electronics and appliances.

EPS packaging is considered a problematic and unnecessary single use plastic because it is not recyclable using kerbside collection systems, there are limited drop-off services to recycle EPS for customers and if littered, it has a high environmental impact.

This phase out does not apply to polystyrene and/or plastic foam products that we sell, such as bean bag fill and decorating foam. Currently we are only phasing out EPS in business to consumer packaging.

## ENVIRONMENTAL CLAIMS

Many consumers consider environmental claims as a major factor when evaluating products to purchase. Therefore, it is essential that consumers are provided with accurate information in order to make informed decisions. Environmental claims are statements, symbols, graphics, or any combination of these that indicate the environmental aspects of a product or service to the market and consumers. These claims come in a wide range of forms, including statements about environmental sustainability, recycling, energy and water efficiency or impact on animals and the natural environment.

Environmental and sustainability claims are a current priority for the Australian Competition and Consumer Commission (ACCC) and are high risk. You must ensure that you do not make misleading or deceptive environmental, sustainability or green claims. **Heavy penalties can apply.**

Companies or brands which make environmental or 'green' claims should ensure that their claims are scientifically sound and appropriately substantiated. If you wish to make environmental claims about a product, they should be honest, accurate and able to be substantiated. You should clearly explain, in simple language, the significance of the benefit to the environment.

Terms such as 'green', 'environmentally safe' and 'fully recycled' are broad terms that may have more than one meaning. For example, the statement 'safe for the environment' could have many meanings depending on the audience, some may believe this means your product is biodegradable or others may infer that it contains non-toxic ingredients. If a consumer's understanding, inferred from the terms used, conflicts with the facts then they may be misled. To avoid misleading consumers, make sure that you explicitly identify and accurately convey any 'green' attributes.

There may be proof or evidence required to allow the making of environmental claims or the use of logos/symbols such as:

- certifications and other evidence obtained independently or from suppliers (such as factory Scope certificates and Transaction certificates);
- information noted in technical specifications to support claims;
- environmental impact evaluations; and/or
- other evidence to back comparisons or references to other products or services (comparison claims).

It will not be sufficient to make claims based on the unsubstantiated word of the supplier.

You should also be careful that the overall impression you create about the goods or services you sell is not misleading. In other words, it is not enough for each representation to be technically or narrowly correct. It is just as important to look at the overall impression created in the minds of average consumers in the target audience.

## Some Important Do's & Don'ts

### **DON'T:**

- Mislead consumers - all environmental claims made must be accurate, verifiable, relevant, and not misleading.
- Overstate or exaggerate the environmental benefit - that is being claimed by the product or service. Any claims must consider the environmental loads of a product or service throughout its entire life cycle. You must not overstate the benefits or implications of a certification program.
- Claim a business is 'certified' by a scheme when only some of its products are certified, and not the entire business. Also don't use the word 'certified' used in relation to an entire product, when only certain components of the product are certified.
- Use short and snappy slogans and claims - that do not give a proper explanation of the environmental claims that are being made.
- Use comparative claims (or avoid these if possible) - as these are high risk and the reproducible and repeatable scientific evidence used to support a claim must be available (on hand) when the claim is made. Do not make a claim if you cannot readily verify it claim and show the evidence.
- Use qualifying information to try to displace the overall impression - Consider the wording, slogans or trademarks used. Usually, an explanatory statement or qualifying statement that accompanies the main claim, must be adjacent to the main claim with comparable font size, font colour and background colour.

### **DO:**

- Avoid general terms - like 'environmentally friendly,' 'green,' or 'sustainable' which may mislead consumers. Also 100% claims (e.g. 100% organic, 100% recycled etc) need to be carefully checked to ensure they are accurate.
- Be specific - the environmental claim should refer to a specific product, product range, service, or process.
- Have the evidence on hand - the evidence and information to support the claim must be on hand/ readily available at the time the claim is made. Do not leave it until the product is ready to launch and the claims are already made to then start checking you have the evidence you need.
- Take responsibility for the claims you make - you must evaluate the evidence/data you have to make the claim yourself. Verification and credibility of the claim remains with the person making the claim. You cannot just rely on the unsubstantiated word of a supplier.
- Include information near the relevant claims - this can be by way of accessible click-through links or other means that give consumers information.
- Present evidence in a way that is easy to understand - avoid complex scientific language or links to complex information. Understanding claims should not require sophisticated expert knowledge. When a symbol or image is used, it should not overshadow the text claim.



You will be supplied with a printed KOO Kids colour swatch.

This will swatch will have the main KOO Kids Pantone 7547 as well as all the colours of the KOO Kids logo.

This is to be used to compare printed packaging to ensure colour consistency throughout the KOO Kids range. All packaging must closely match the colours of this swatch so the KOO Kids range is cohesive in store.

# PACKAGING CHECKLIST

The packaging checklist as seen here must be looked through and checked off whenever working on packaging artwork to assure all packaging artwork is clear, legible, and accurate and all colours, typefaces and logos match those laid out within the brand guidelines document.

If it is the first time any particular product type has been produced or there has been brand update a physical printed copy of the packaging must to the relevant buyer or assistant for approval.

It is important that you have a signed/approved sample of your packaging and that you've specified all the above details within the checklist in a previous run. Material and printing should be verified, packaging should be measured, and colors should match your Pantone colour specifications.

This signed and approved sample of packaging has been created it important to use this as a key example all other packaging should match back too.

Once everything has been ticked off the packaging must be sent to the relevant buyer or assistant for final approval.

## PRINTING SPECIFICATIONS KEY

The below key will be placed on all packaging templates so all key printing information such as paper stock GSM, finish and any other extra information like a spot UV or foiling is on the artwork itself. Please always refer to this key for colour and paper finish specifications.

|  |  |
|--|--|
| <b>FINISH</b> <input type="checkbox"/> GLOSS <input checked="" type="checkbox"/> MATTE <input type="checkbox"/> OTHER _____<br><b>COATING</b> <input type="checkbox"/> SPOT UV <input type="checkbox"/> FOIL <input type="checkbox"/> OTHER _____<br><b>PAPER STOCK (GSM)</b> _____<br><b>DIELINE MEASUREMENTS</b> _____ |  |
|--|--|

## PACKAGING SIGN OFF

All artwork must be sent to Spotlight for approval before printing.

Suppliers – please send artwork to the relevant buyer or assistant. Please use this guide as a reference for all KOO products.

### PACKAGING CHECKLIST

#### LOGO

- It is important that the appearance of the logo remains consistent. Its orientation, colours and composition should remain as indicated in the brand guidelines document.

#### COLOUR

- Pantone & CMYK colors are consistent with those outlined in the brand guidelines .
- Colours are consistent with printed packaging example provided.

#### TYPEFACES & FONTS

- Typeface, font type and size are consistent with those outlined in the brand guidelines.

#### DIMENSIONS

- Are packaging dimensions consistent with those outlined in the brand guidelines.
- Do the dimensions of the product packaging allow it to be safe/secure.

#### COPY & MANDATORY INFORMATION

- Proofread the copy
- Barcode and Item number
- Import Information & Country of Origin
- Care & Use
- All labeling is clear, legible, and accurate
- Warning if applicable

#### IMAGERY

- Does image clearly show the product contained within the packaging.
- Does the lighting and colours of the image match those of the product.
- Is image of high quality.
- Does the photography suit the brand guidelines.

#### CARD AND PAPER STOCK QUALITY/FINISH

- Does the finish of the card stock used match that outlined within the brand guidelines.
- Does the GSM of the card stock range between 250-400gsm depending on the individual product. With the ideal usually being around 350gsm for most products.  
\* There are some exceptions to this such and dinner sets and glassware set packaging which should be as thick as required to ensure the products safety as well as maintain the boxes structural integrity.
- Physical samples are to be sent for approval of quality and colour on the first run of each new set of packaging before mass production begins.

## PRODUCT INFORMATION

**Product Dimensions** must be displayed on all applicable packaging. This should be on the front of the packaging on all products that require customer to be sure of product sizing (e.g. dimensions for bed linen).

**Set Includes** must also be shown clearly on the front of all applicable products (e.g. 1x Quilt Cover & 2x Standard Pillow Cases).

**Product Composition** it is important to articulate the materials that have been used in the fabrication of a product. For products such as manchester this is critical information and should be shown on the front of the pack.

**Icons** should be shown on the front of the packaging where applicable, please see icons page for further reference.

**Care Instructions and Icons** must be included on all products, especially manchester and table top products. All labels must include washing or care instructions. Please ensure that the wording for these instructions is simple and easy to understand. Please ensure that 'Dry Cleanable', 'Do Not Dry Clean' and 'Food Safe' symbols are use where appropriate.

These instructions must also be included on the care tag and on the backstamp of these products. Please see care label and backstamp page for further information.

## ADDRESS AND COUNTRY OF ORIGIN

The Spotlight Support Office address details must be included on all packaging and labels as well as the country of origin (where the product was made).

There are 2 layout options depending on the available space.

|  |  |                    |
|--|--|--------------------|
| <b>Imported by</b><br>KOO Home Store, 111 Cecil Street,<br>South Melbourne, VIC Australia 3205 | <b>Imported by</b><br>KOO Home Store,<br>111 Cecil Street,<br>South Melbourne,<br>VIC Australia 3205 | Graphie - Bold 6pt |
| <b>Made in China</b>   | <b>Made in China</b>   | Graphie - Book 6pt |
|  |  | Graphie - Bold 6pt |

## PRODUCT WARNINGS

Some products will require a warning to highlight potential safety risks to consumers.

These risks may relate to the packaging materials (e.g. the risk of suffocation from plastic covering used to package the product or the actual product (e.g. the risk of suffocation from bean bag filling or the risk of fire from candles).

It is the responsibility of the Merchandise team to ensure the correct warning is in place. Warnings must be clearly visible on the packaging.

**WARNING:** Please keep packaging away from children. Plastic covering may cause a suffocation.

**Red Text:**  
M 100 Y 100.

**Minimum Text Size:**  
8pt/10pt leading.  
Font must be sans serif.

**WARNING:**  
Must be in bold.

**Red Stroke:**  
1pt (around the text box).

For large packaging formats, such as 'Bean Bag Fill', the warning is to be scaled up to an appropriate size so that it is clearly visible at a glance.



## BARCODE

A unique barcode must appear on all products. It is essential that the size and print specifications for barcodes are followed to ensure they are able to be scanned.

All Spotlight products require a EAN-13 barcode and it must meet GS1 specifications.

The barcode must be placed within a white area on the packaging label.

**White Area: 37.29mm (W) x 25.93mm (H)**

**Barcode: 31.35mm (W) x 22.85mm (H)**

If the barcode is required to be smaller to suit the product, DO NOT reduce the above size by more than 80%.

DO NOT shorten the height of the barcode.

Where possible the barcode should be positioned on the back of the packaging on the bottom right hand corner of the pack.

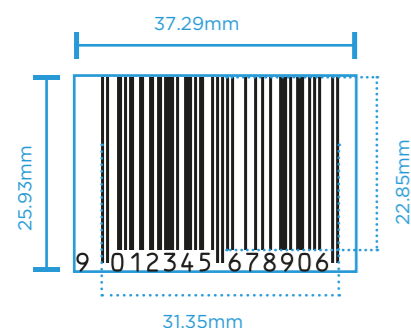

## BARCODE STICKER

In the majority of applications the barcode is to be applied to the packaging as a self adhesive label.

This allows products that come in a variety of colours and sizes to utilise the same packaging and have individual barcodes to be applied to them.

It also allows for **batch numbers/order numbers** to be allocated to packaging, enabling products to be tracked to help ensure that the continuity of colour and quality is maintained between different orders.

The sticker has space for **style** and **colour** information to be added, if required. **Pricing** information can also be displayed on the sticker, but only when requested by the buyer.

When designing the packaging available for the barcode sticker, allow 5mm clear space around it for movement in its application.



## PRODUCT INFORMATION

All textile products such as bedding, napery and other manchester must include a sewn in care label.

This label must include all the details below such as the KOO logo, the product compositions such as 100% cotton, 100% polyester for example, and care and use such as do not bleach, line dry, hand wash only etc as well as the product information and country of origin.

Example as per below.

Supplier is required to update material, care instructions and country of origin to create artwork for product.

## FABRIC WASHING INSTRUCTION ICONS



### KOO Double Sided Care Label

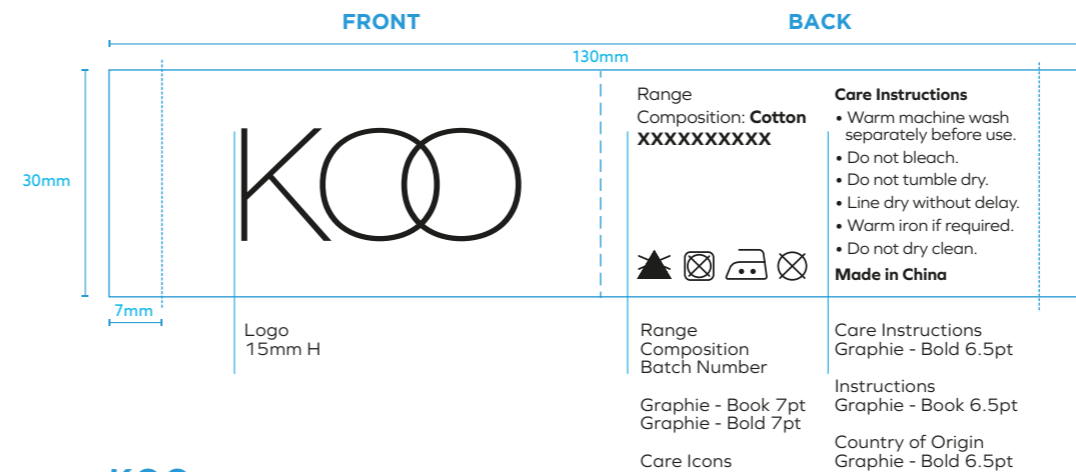

### KOO Double Sided Size Label

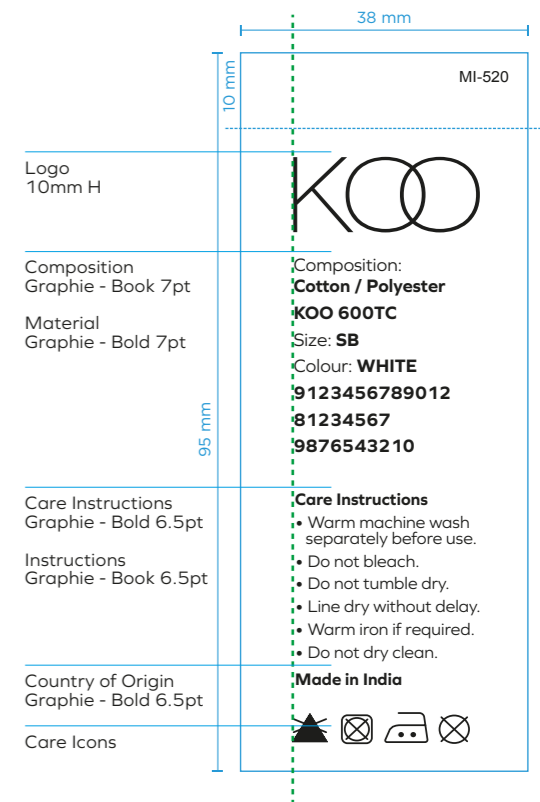





**IMPORTANT - Dieline is for visual purposes only and needs to be updated by supplier. All information on example must be included when generating new artwork for product.**

ARTWORK SCALE: 60%

**BACK PANEL**

- Barcode
- Address
- Care Instructions - Written & Care Icons
- Composition
- Photography Note
- Graphic - 6pt

50mm

217mm  
To change to suit product

Full Height of example 327mm

60mm

**TOP PANEL**

Logo Sizing Icon  
\*Note there are more rules for what is to be included when the width of the top panel is above 120mm, please see the next page for further details

**FRONT PANEL**

Logo Sizing Icon

Product Name (Title Case)  
Graphic Book - 40pt

Product Description (Title Case)  
Graphic Bold - 40pt

Inclusions  
Graphic Bold - 10pt  
Inclusions Size  
Graphic Book - 10pt

Composition  
Graphic Book - 10pt  
Material/s  
Graphic Bold - 10pt

Logo 20mm High

10mm

Logo 20mm High

10mm

10mm

10mm

230mm  
packaging width must be full width of the product

55 - 120mm  
To change to suit product

120mm

**SIZE ICONS**

**FULL DIELINE CONFIGURATION**

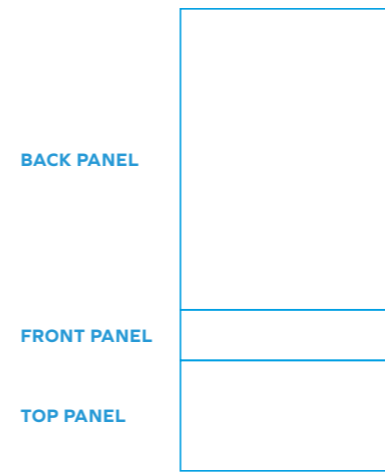

S  
SINGLE

D  
DOUBLE

Q  
QUEEN

K  
KING

Q/K  
QUEEN / KING

25mm

45mm

25mm

Sizing Icon  
Graphic Bold - 60pt  
Size Description  
Graphic Bold - 13pt



# QUILT COVER BAGGED PACKAGING - SEWN ON

Dieline size must be the same across all products to maintain consistency.

**IMPORTANT - Dieline is for visual purposes only and needs to be updated by supplier. All information on example must be included when generating new artwork for product.**

Packaging and bag design must always be designed in portrait. Tie for the bagged quilt must be at the top.

ARTWORK SCALE: 60%

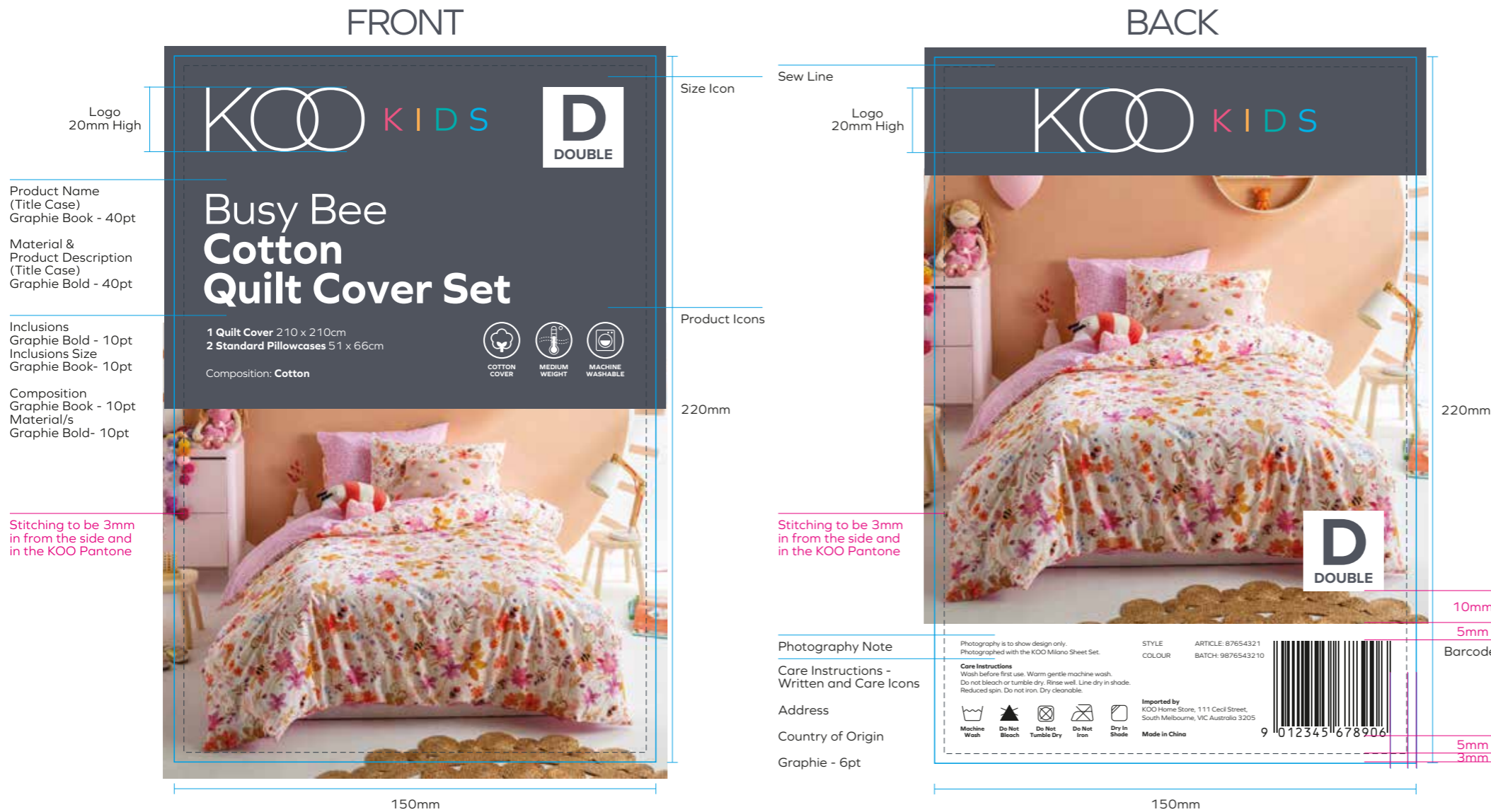

## SIZE ICONS

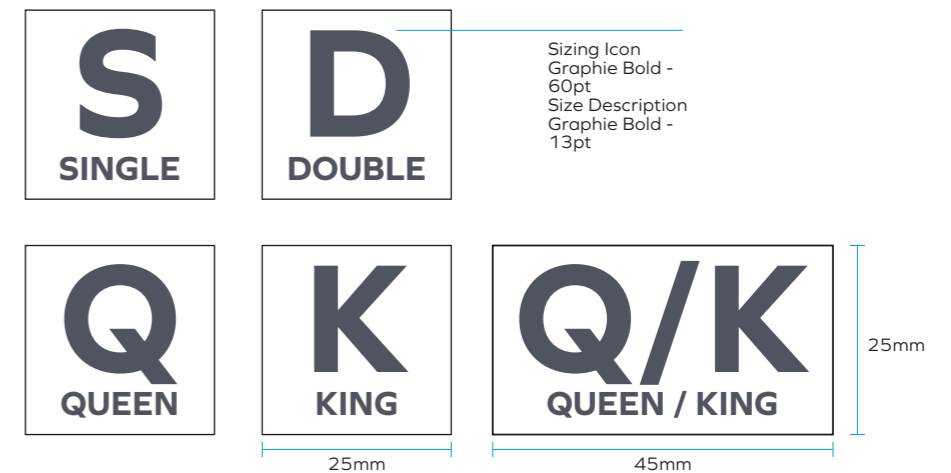





**IMPORTANT - Dieline is for visual purposes only and needs to be updated by supplier. All information on example must be included when generating new artwork for product.**

ARTWORK SCALE: 70%





KOO KIDS **D**  
DOUBLE

**Gingham  
Cotton  
Sheet Set**

1 Flat Sheet 245 x 265cm  
1 Fitted Sheet 152 x 203 x 40cm  
2 Standard Pillowcases 48 x 74cm

Composition: 225 Thread Count Cotton



KOO KIDS

**Caratteristiche**  
Materiale: 100% Cotone  
Cottura: 100°C / 212°F  
Non stirare  
Non candire  
Non sbiancare  
Non asciugare in asciugatrice  
Non stirare a secco  
Non lavare a secco

**Caratteristiche**  
Materiale: 100% Cotone  
Cottura: 100°C / 212°F  
Non stirare  
Non candire  
Non sbiancare  
Non asciugare in asciugatrice  
Non stirare a secco  
Non lavare a secco

9 012345 678900

# SHEETS BAGGED PACKAGING - SEWN ON

Dieline size must be the same across all products to maintain consistency.

The bag should tie at the top with the labels centred with the front and back panels.

**IMPORTANT - Dieline is for visual purposes only and needs to be updated by supplier. All information on example must be included when generating new artwork for product.**

ARTWORK SCALE: 100%

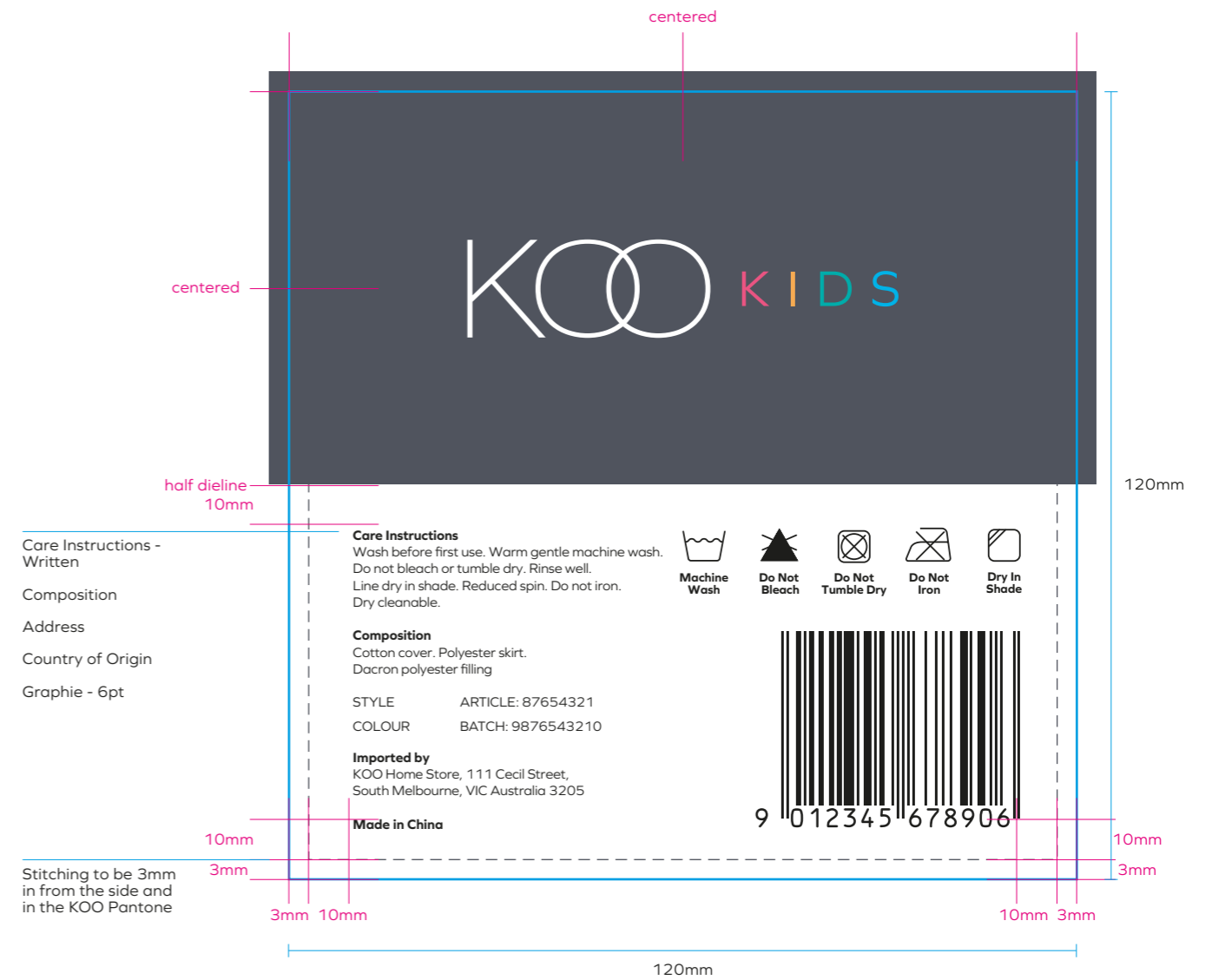



**IMPORTANT - Dieline is for visual purposes only and needs to be updated by supplier. All information on example must be included when generating new artwork for product.**

ARTWORK SCALE: 100%

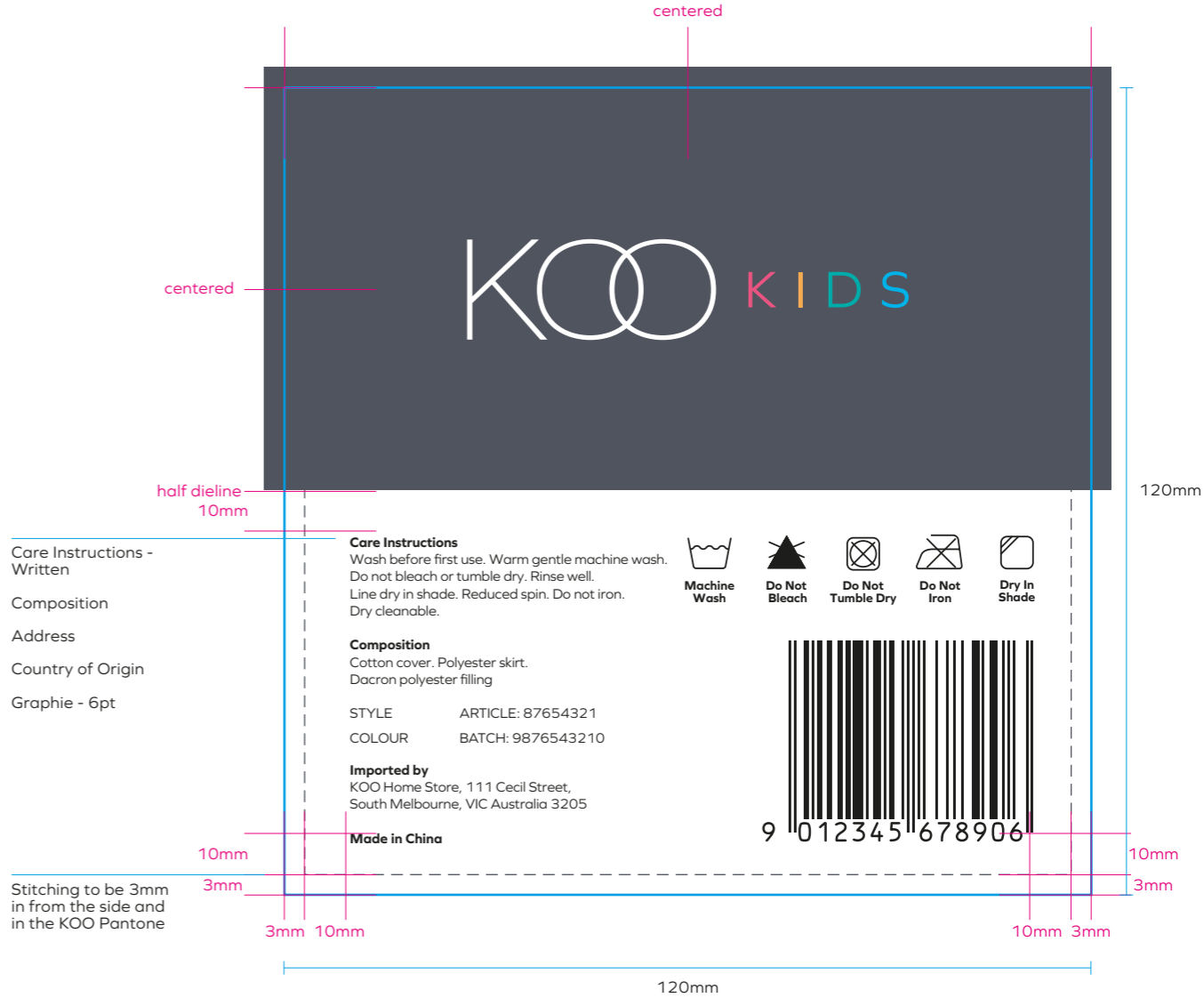



**IMPORTANT - Dieline is for visual purposes only and needs to be updated by supplier. All information on example must be included when generating new artwork for product.**

ARTWORK SCALE: 60%

**Logo**  
25mm High

10mm

10mm

10mm

**KOO KIDS**

**Pom Pom Sheer Curtains**

1 Pair of Curtains  
To fit a window 140-220cm wide  
Drop 223cm  
Colour White

Composition: Polyester Cotton

Versatile curtain that can be hung in 3 ways

SHYER DESIGN CONCEALED ROD PENCIL PLEAT

Product Name  
Graphie Book - 40pt

Product Description  
Graphie Bold - 40pt

Inclusions  
Graphie Bold - 10pt  
Inclusions Size  
Graphie Book- 10pt

Composition  
Graphie Book - 10pt  
Material/s  
Graphie Bold- 10pt

centered

**Instructions**  
Graphie - 6pt

**Care Instructions - Written**  
Graphie - 6pt

**Care Icons**

**WARNING**  
Curtain and blind cords have caused the death of young children and must be installed so that they are not a strangulation hazard. Follow the installation instructions.

Photography note

Warning if required

Address

Country of Origin  
Graphie - 6pt

Barcode

365mm  
Packaging height must be full length of the product

120mm

74mm  
To change to suit product

120mm

5mm

**IMPORTANT - Dieline is for visual purposes only and needs to be updated by supplier. All information on example must be included when generating new artwork for product.**

ARTWORK SCALE: 70%

**Product Name**  
Graphie Book - 25pt

**Product Description**  
Graphie Bold - 25pt

**Inclusions**  
Graphie Bold - 7pt  
Inclusions Size  
Graphie Book- 7pt

**Composition**  
Graphie Book - 7pt  
Material/s  
Graphie Bold- 7pt

**Callouts**  
Graphie Book - 7pt

**Image**  
Logo  
20mm High

**Measurement & Extension Diagram**

**Icons**

**Icon Text**  
Graphie - 6pt

**Address**

**Country of Origin**  
Graphie - 6pt

**Barcode**

**Expandable Poles**  
2 1.9 x 130cm and 1 2.2 x 130cm  
2 Finials  
3 Brackets with Screws

**Composition: Trumpet Nickel**

Adjustable in width to suit your windows  
Expandable from 132cm to 360cm  
Simple DIY installation - no cutting required!  
Sturdy Construction  
Suitable for light to medium weight curtains

**165-300cm**  
165cm 300cm

**CURTAIN TYPES**

PENCIL PLEAT PINCH PLEAT  
EYELET ROD POCKET TAB TOP

Curtain rings included. Will hang pencil and pinch pleat. Hooks sold separately.  
No rings required.

**STYLE** ARTICLE: 87654321  
**COLOUR** BATCH: 9876543210

**Imported by**  
KOO Home Store, 111 Ceell Street,  
South Melbourne, VIC Australia 3205

**Made in China**

9 012345 678906





**IMPORTANT - Dieline is for visual purposes only and needs to be updated by supplier. All information on example must be included when generating new artwork for product.**

ARTWORK SCALE: 80%

**FRONT OPTION 1**

Product Name (Title Case) Graphie Book - 40pt

Product Description (Title Case) Graphie Bold - 40pt

Inclusions Graphie Bold - 10pt  
Inclusions Size Graphie Book- 10pt

Composition Graphie Book - 10pt  
Material/s Graphie Bold- 10pt

**Fleece Throw 120 x 200mm**

Composition: **Cotton/Polyester**

120mm

225mm

half dieline

**FRONT OPTION 2**

Product Name (Title Case) Graphie Book - 40pt

Product Description (Title Case) Graphie Bold - 40pt

Inclusions Graphie Bold - 10pt  
Inclusions Size Graphie Book- 10pt

Composition Graphie Book - 10pt  
Material/s Graphie Bold- 10pt

**Fleece Throw 120 x 200mm**

Composition: **Cotton/Polyester**

120mm

centred

**BACK**

Care Instructions - Written

Composition

Address

Country of Origin

Graphie - 6pt

**Care Instructions**  
Wash before first use. Warm gentle machine wash. Do not bleach or tumble dry. Rinse well. Line dry in shade. Reduced spin. Do not iron. Dry cleanable.

Machine Wash Do Not Bleach Do Not Tumble Dry Do Not Iron Dry In Shade

STYLE ARTICLE: 87654321  
COLOUR BATCH: 9876543210

Imported by  
KOO Home Store, 111 Cecil Street,  
South Melbourne, VIC Australia 3205

Made in China

9 012345 678906

120mm

120mm

half dieline

# THROW PACKAGING - WRAP OPTION

**IMPORTANT - Dieline is for visual purposes only and needs to be updated by supplier. All information on example must be included when generating new artwork for product.**

ARTWORK SCALE: 80%

**Product Name (Title Case)**  
Graphie Book - 40pt

**Product Description (Title Case)**  
Graphie Bold - 40pt

**Inclusions**  
Graphie Bold - 10pt  
Inclusions Size  
Graphie Book- 10pt

**Composition**  
Graphie Book - 10pt  
Material/s  
Graphie Bold- 10pt

**120 x 200mm**

**Composition: Cotton/Polyester**

**290mm**  
Length can change to suit the product as long as text/logo etc stays consistent

**Care Instructions - Written**  
Graphie - 6pt

**Care Icons**

**Address**  
Country of Origin  
Graphie - 6pt  
Barcode

**Care Instructions**  
Wash before first use. Warm gentle machine wash. Do not bleach or tumble dry. Rinse well. Line dry in shade. Reduced spin. Do not iron. Dry cleanable.

**Machine Wash** **Do Not Bleach** **Do Not Tumble Dry** **Do Not Iron** **Dry In Shade**

**STYLE**  
**COLOUR**

**ARTICLE:** 87654321  
**BATCH:** 9876543210

**Imported by**  
KOO Home Store, 111 Cecil Street,  
South Melbourne, VIC Australia 3205

**Made in China**

9 012345 678906

**OVERLAP (GLUE AREA)**

10mm, 10mm, 10mm, 10mm, 10mm, 10mm, 10mm, 10mm, 100mm, 20mm, 140mm, 10mm

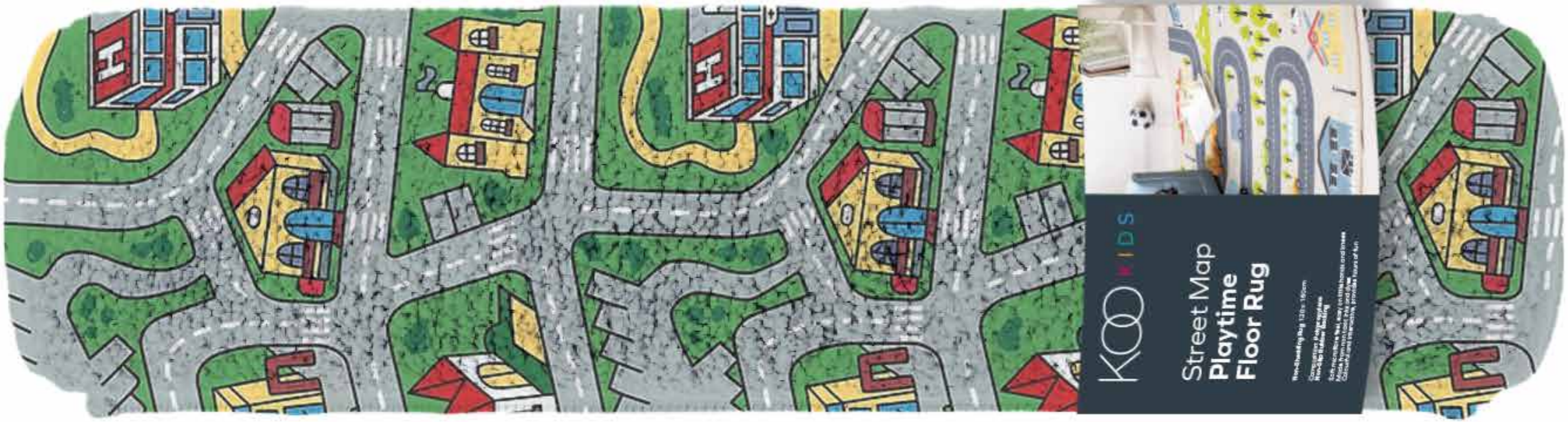

KOO KIDS

Street Map  
Playtime  
Floor Rug

Handmade Rug, 120" x 160"  
Cotton and Polypropylene  
Machine Washable  
Soft and Safe for Kids  
Cotton and Polypropylene  
Cotton and Polypropylene



# RUG WRAP PACKAGING

Dieline height must be the same across all products to maintain consistency.

Wrap must be placed at the base of the rug so the wrap label can be seen clearly when stacked lying down in the shelving in store.

**IMPORTANT - Dieline is for visual purposes only and needs to be updated by supplier. All information on example must be included when generating new artwork for product.**

ARTWORK SCALE: 80%

**Product Name (Title Case)**  
Graphie Book - 40pt

**Product Description (Title Case)**  
Graphie Bold - 40pt

**Inclusions**  
Graphie Bold - 10pt  
Inclusions Size  
Graphie Book- 10pt

**Composition**  
Graphie Book - 10pt  
Material/s  
Graphie Bold- 10pt

**Non-Shedding Rug 120 x 160cm**

**Composition: Polypropylene**  
**Non-Slip Rubber Backing**

Soft microfiber feel, easy on little hands and knees  
Made from non toxic inks and dyes  
Colourful and interactive, provides hours of fun

**Care Instructions**  
Vacuum regularly. Spot clean by blotting spills with a paper towel or colourless cloth. Professional cleaning recommended.

**Care Icons:**  
Professional Cleaning (circle with dot), Do Not Bleach (triangle with slash), Do Not Tumble Dry (square with slash), Do Not Iron (square with slash), Dry In Shade (square with slash).

New rugs, particularly those that include wool fibers, are susceptible to shedding. With care & treatment most rugs should stop shedding within 2-3 months.

**STYLE** ARTICLE: 87654321  
**COLOUR** BATCH: 9876543210

**Imported by**  
KOO Home Store, 111 Cecil Street,  
South Melbourne, VIC Australia 3205

**Made in China**

Barcode: 9 012345 678906

**OVERLAP (GLUE AREA)**

Dimensions: 10mm, 290mm, 10mm, 100mm, 20mm, 150mm, 10mm.

Note: Length can change to suit the product as long as text/logo etc stays consistent



# TOWEL PACKAGING

This packaging is to be tied to the product using a ribbon.

For product that have an image that cannot be seen while folded rather than a simple pattern an image of the full towel is to be included on a separate tag.

**IMPORTANT - Dieline is for visual purposes only and needs to be updated by supplier. All information on example must be included when generating new artwork for product.**

ARTWORK SCALE: 80%

### ADDITIONAL TAG WHEN NEEDED

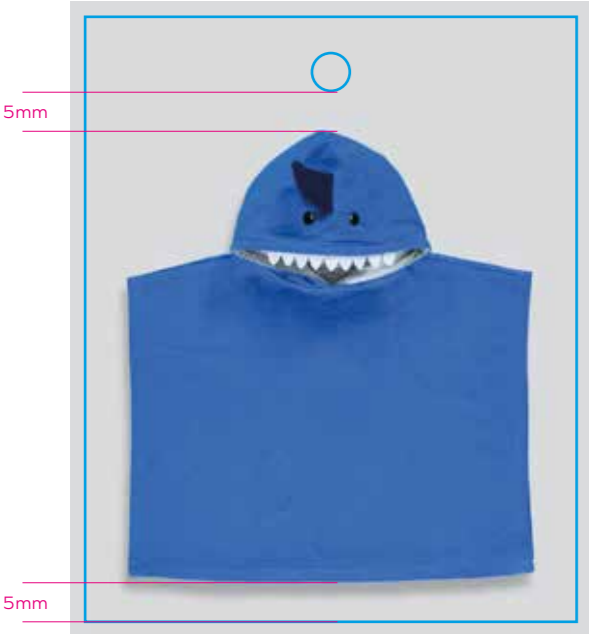

5mm 3mm 5mm

5mm  
3mm  
5mm

Logo  
20mm High

Product Name  
Graphie Book - 40pt

Product Description  
Graphie Bold - 40pt

**KOO KIDS**

**Shark  
Hooded  
Bath Towel**

139 x 69cm

Composition: **Microfibre**

Inclusions  
Graphie Bold - 10pt  
Inclusions Size  
Graphie Book - 10pt

Composition  
Graphie Book - 10pt  
Material/s  
Graphie Bold - 10pt

120mm  
half dieline

**Care Instructions**  
Wash separately before first use. Cold gentle machine wash. Wash with similar colours. Do not bleach, soak or wring. Do not iron. Do not tumble dry. Do not dry clean.

**Imported by**  
KOO Home Store, 111 Cecil Street,  
South Melbourne, VIC Australia 3205

**Made in China**

Machine Wash Do Not Bleach Do Not Soak Do Not Wring  
Do Not Iron Do Not Tumble Dry Do Not Dry Clean

STYLE ARTICLE: 87654321  
COLOUR BATCH: 9876543210

9 012345 678906

Care Instructions - Written  
Composition  
Address  
Country of Origin  
Graphie - 6pt

120mm

**IMPORTANT - Dieline is for visual purposes only and needs to be updated by supplier. All information on example must be included when generating new artwork for product.**

ARTWORK SCALE: 80%







KOO KIDS

Quick Dry  
Mermaid  
Beach Towel

130 x 60cm  
Composition: Egyptian Cotton



# TOWEL PACKAGING - EDGE LABEL

Dieline size must be the same across all products to maintain consistency.

**IMPORTANT - Dieline is for visual purposes only and needs to be updated by supplier. All information on example must be included when generating new artwork for product.**

## TOWELS THAT ARE NOT A PLAIN COLOUR

This label is slightly wider to accommodate an image of the towel so any patterns or artwork can be clearly seen as per example below.

ARTWORK SCALE: 100%

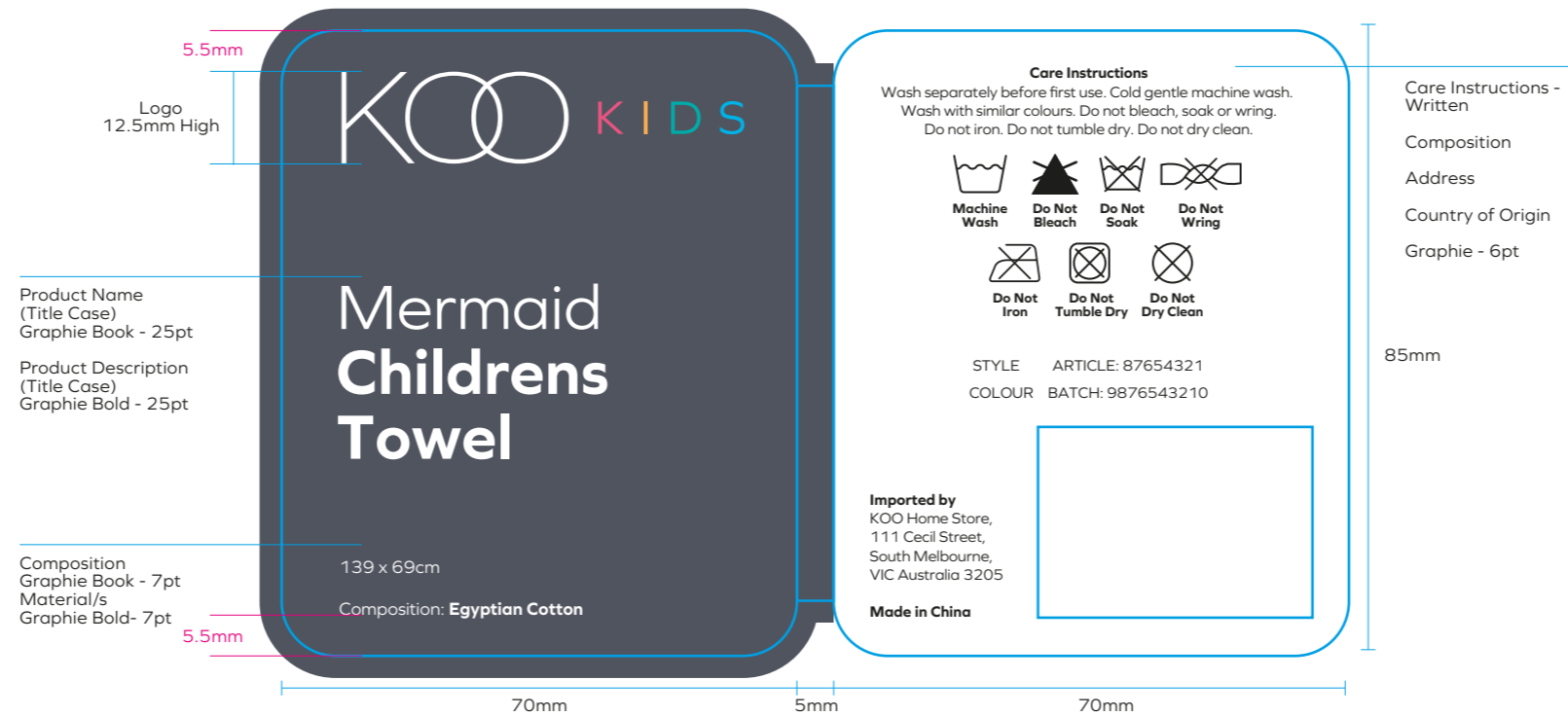

## TOWELS THAT ARE NOT A PLAIN COLOUR



KOO KIDS

Rainbow  
Cotton  
Cushion Cover

50 x 50cm

Composition: Polyester/Cotton



**IMPORTANT - Dieline is for visual purposes only and needs to be updated by supplier. All information on example must be included when generating new artwork for product.**

ARTWORK SCALE: 100%





**IMPORTANT - Dieline is for visual purposes only and needs to be updated by supplier. All information on example must be included when generating new artwork for product.**

ARTWORK SCALE: 100%

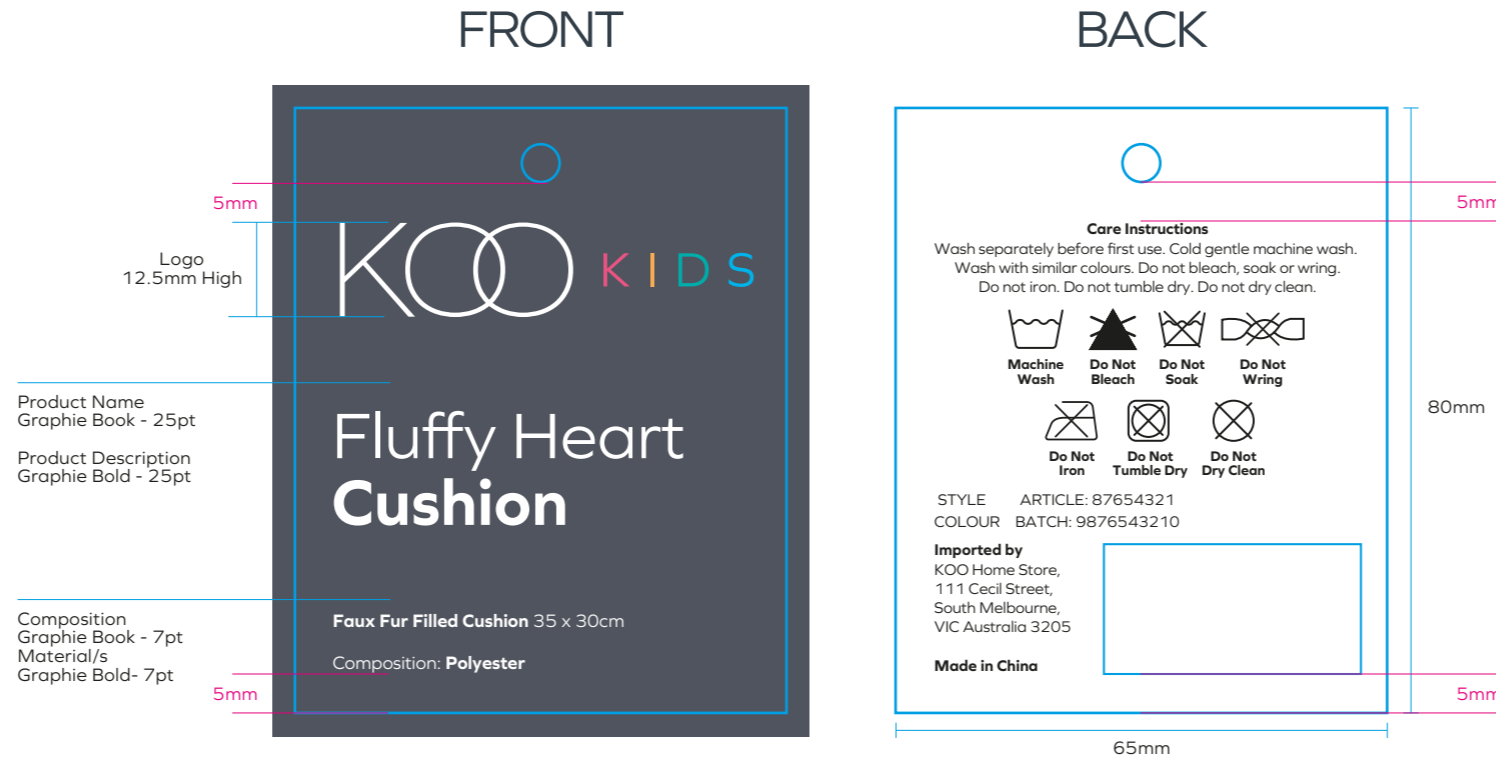

STICKER

